



Technology you can trust

NAC Linear Fixtures

Simple solutions for big savings. NAC's LED linear fixtures provide crisp, uniform light, ideal for a wide variety of commercial and industrial applications. With a range of LED battens and linear channel luminaires, these fixtures are an excellent alternative to traditional fluorescent lighting.



BATTEN LUMINAIRES

Providing the safety and security of light when you need it – saving energy when you don't. NAC's LED batten fixtures provide crisp, clear light when motion is detected and dim to 33% output when it isn't, saving money and energy. With heavy-duty, powder coated, galvanized metal housings and the option for surface or suspended chain installation, NAC LED battens are ideal for stairwells, passageways and parking garages, or any area with intermittent traffic. The Batten Luminaire with Emergency Backup (99585) features an integrated long life battery, including test switch, which provides functional light for a minimum of 90 minutes in the event of power loss. Backed by a 5-year limited warranty, NAC LED battens have an estimated design lifetime of 50,000 hours, resulting in reduced maintenance and replacement costs when compared to fluorescent fixtures.

FEATURES & BENEFITS

- Dual infrared motion sensors – mounted on each end of fixture for accurate motion detection, rotate to optimize desired coverage
- Bi-level operation – 3000lm/26W full on, 1000lm/8.6W standby mode
- Batten with Emergency Backup (99585) features an integrated long life battery, including test switch, which provides functional light for a minimum of 90 minutes in the event of power loss
- On time and detection zone are adjustable using optional remote control (Sold separately: #98892)
- Ideal for stairwells, passageways, parking garages
- High efficacy
- Heavy-duty, powder coated galvanized metal housing
- Suitable for surface or suspended (chain) mounting; side and base knockouts provided for ceiling or wall mounting
- Includes mounting hardware: junction box adapter plate, v-hooks and chain
- 100-277V compatible
- Available in 5000K
- 50,000 hour minimum design lifetime
- 5-Year Limited Warranty

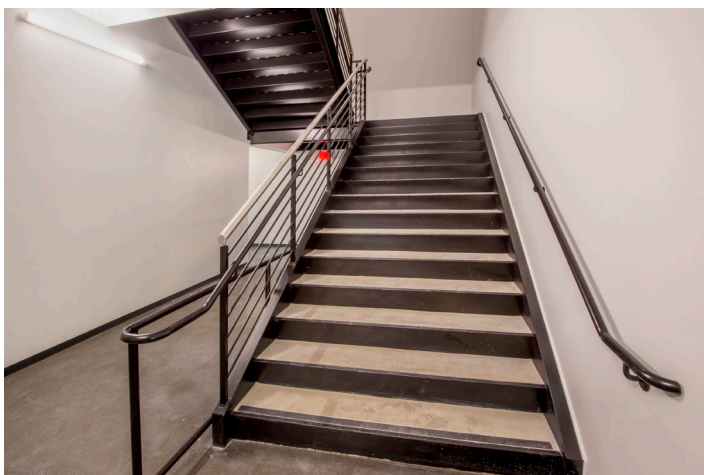

CERTIFICATIONS



Stairway and passageway luminaires

SPECIFICATIONS

NAC PART #	DESCRIPTION	TYPE	DLC	COLOR TEMP	LUMEN OUTPUT	WATTAGE	DESIGN LIFETIME (HRS)	DIMMING	INPUT VOLTAGE
99305	BAT-4FT-W26-C50-MS-NON	4 ft. Batten with dual motion sensor	✓	5000K	3000lm (Full illumination) 1000lm (Stand-by mode)	26W (Full illumination) 8.6W (Standby mode)	50,000	Bi-level	100-277V
99585	BAT-4FT-W26-C50-MS-NON-EM	4 ft. LED Batten Luminaire with Dual Motion Sensors and Emergency Backup	✓	5000K	3000lm (Full illumination) 1000lm (Stand-by mode)	26.5W (Full illumination) 8.6W (Standby mode)	50,000	Bi-level	100-277V

DIMENSIONS

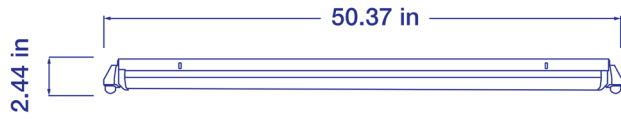

99305

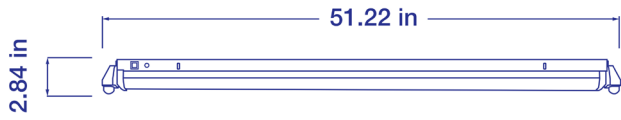

99585

BEAM ANGLE

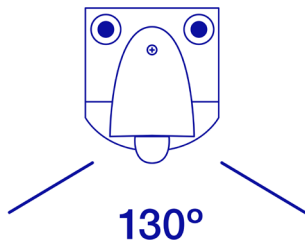

99305, 99585

POLAR CANDELA DISTRIBUTION

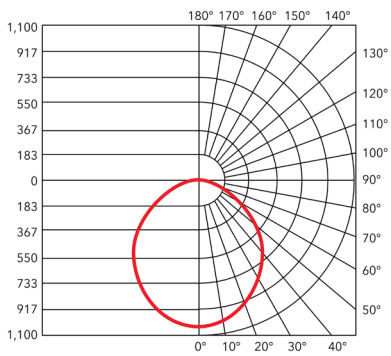

99305



Technology you can trust



LINEAR CHANNEL LUMINAIRE

Lighting made simple. NAC's LED linear channel luminaires provide crisp, uniform light, ideal for a wide variety of commercial and industrial applications. Highly-efficient, these fixtures are cost-effective replacements for 4 ft. or 8 ft. fluorescent tube fixtures in high-traffic, constant light areas – saving up to 50% in energy costs. NAC LED Linear Channel Luminaires come standard with 0-10V dimming and are compatible with most sensors and systems used to achieve further energy savings. Featuring durable powder coated steel housings with integrated LED channel, these luminaires are easy to install with multiple screw slots and knockout locations. Backed by NAC's 5-year limited warranty, the LED Linear Channel Luminaires have a rated life of 50,000 hours, resulting in reduced maintenance and replacement costs when compared to fluorescent fixtures.

FEATURES & BENEFITS

- Can replace 4 ft. or 8 ft. fluorescent tube fixtures
- High efficacy – saves up to 50% in energy costs compared to fluorescent
- Frosted diffuser minimizes glare for optimal comfort
- Excellent solution for a variety of environments including warehouses, manufacturing facilities, parking garages, storage areas and more
- Available in 4000K and 5000K
- Durable powder coated steel construction with integrated LED channel
- Simple surface mount installation with multiple screw slots and knockouts. Jbox adapter included.
- 0-10V Dimming – supports compliance with Title 24
- 120-277V compatible
- 50,000 hours rated life
- 5-Year Limited Warranty

CERTIFICATIONS



SPECIFICATIONS

NAC PART #	DESCRIPTION	TYPE	DLC	COLOR TEMP	LUMEN OUTPUT	WATTAGE	DESIGN LIFETIME (HRS)	DIMMING	INPUT VOLTAGE
99588	LN-4FT-W34-C50-010	4 ft. LED Linear Channel Luminaire	Listed	5000K	3850lm	34W	50,000	0-10V Dimming	120-277V
99925	LN-8FT-W68-C40	8 ft. LED Linear Channel Luminaire	Premium	4000K	8640lm	68W			
99926	LN-8FT-W68-C50	8 ft. LED Linear Channel Luminaire		5000K	8700lm				

DIMENSIONS

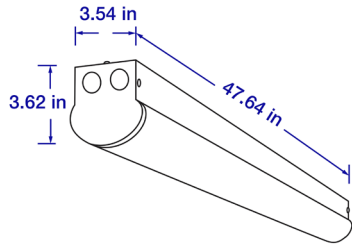

99588

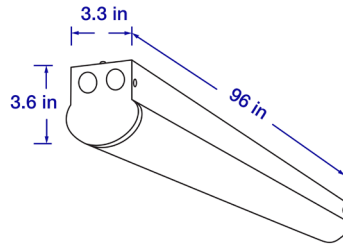

99925, 99926

BEAM ANGLE

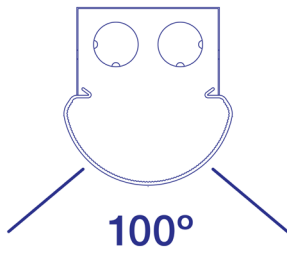

99588, 99925, 99926

POLAR CANDELA DISTRIBUTION

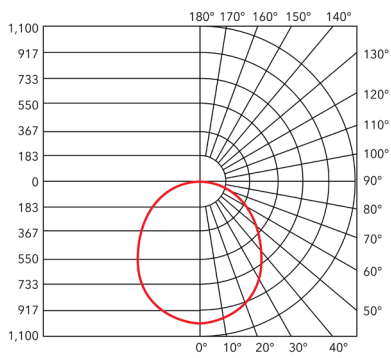

99588



Technology you can trust



LINEAR CHANNEL LUMINAIRE WITH QUICK CLIP INSTALLATION

Lighting made simple. NAC's LED Linear Channel luminaires provide crisp, uniform light, ideal for a wide variety of commercial and industrial applications. Now with quick clip installation, these luminaires are easy to install, saving time and reducing labor costs. The included mounting brackets simplify the installation process, eliminating the need to access the inside of the fixture housing and allowing one person to quickly install the fixture. Highly-efficient, these luminaires are cost-effective replacements for both wall-mounted and suspended fluorescent fixtures, saving up to 50% in energy costs. Available in 4 ft. and 8 ft. lengths, NAC LED Linear Channel luminaires come standard with 0-10V dimming and are compatible with most sensors and systems used to achieve further energy savings. Backed by NAC's 5-year limited warranty, the LED Linear Channel Luminaires have a rated life of 50,000 hours, resulting in reduced maintenance and replacement costs when compared to fluorescent fixtures.

FEATURES & BENEFITS

- Quick clip installation – easily install luminaire without having to access inside of fixture housing
- Can be easily suspended using suspension kit (70300)*
- 4 ft. and 8 ft. lengths available
- 130 lm/W, DLC Premium – saves up to 50% in energy costs compared to fluorescent
- Frosted diffuser minimizes glare for optimal comfort
- Excellent solution for a variety of environments including warehouses, manufacturing facilities, parking garages, storage areas and more
- Available in 4000K and 5000K
- 0-10V Dimming – supports compliance with Title 24
- 100-277V compatible
- 50,000 hours rated life
- 5-Year Limited Warranty

*Sold separately. Includes (2) 4 ft. cables with "V" hooks. 8 ft. fixture requires (2) kits for suspension.

CERTIFICATIONS



SPECIFICATIONS

NAC PART #	DESCRIPTION	TYPE	DLC	COLOR TEMP	LUMEN OUTPUT	WATTAGE	DESIGN LIFETIME (HRS)	DIMMING	INPUT VOLTAGE
70296	LN-4FT-W32-C40-QI	4 ft. LED Linear Channel Luminaire with Quick Clip Installation	Premium	4000K	4160	32W	50,000	0-10V	100-277V
70297	LN-4FT-W32-C50-QI	4 ft. LED Linear Channel Luminaire with Quick Clip Installation		5000K					
70298	LN-8FT-W64-C40-QI	8 ft. LED Linear Channel Luminaire with Quick Clip Installation		4000K	8320	64W			
70299	LN-8FT-W64-C50-QI	8 ft. LED Linear Channel Luminaire with Quick Clip Installation		5000K					

DIMENSIONS

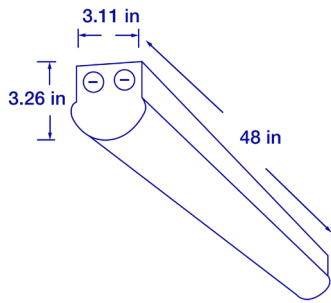

70296, 70297

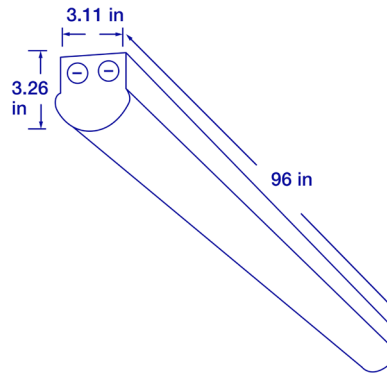

70298, 70299

BEAM ANGLE

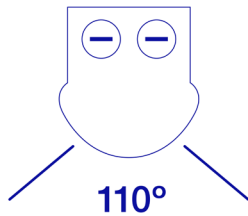

70296-70299

POLAR CANDELA DISTRIBUTION

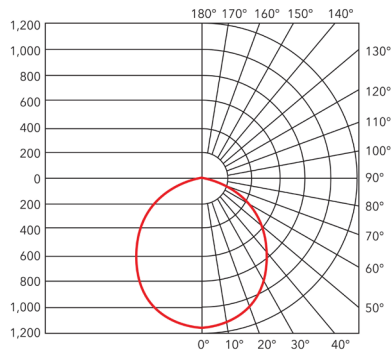

70296, 70298

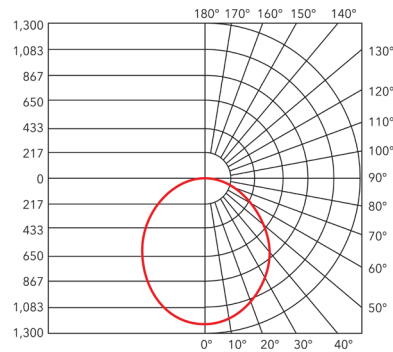

70297, 70299

ACCESSORIES

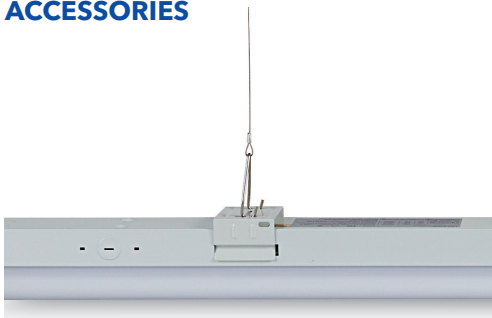

70300
Suspension Kit
Includes (2) 4 ft. cables with "V" hooks. 8 ft. fixture requires (2) kits for suspension.

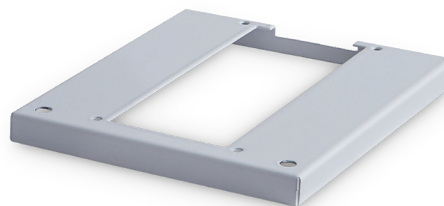

70427
Junction Box Cover